

# SERIES MBV • 2-Way Manual Ball Valves

An engineered true union ball valve for manual and actuated valve applications

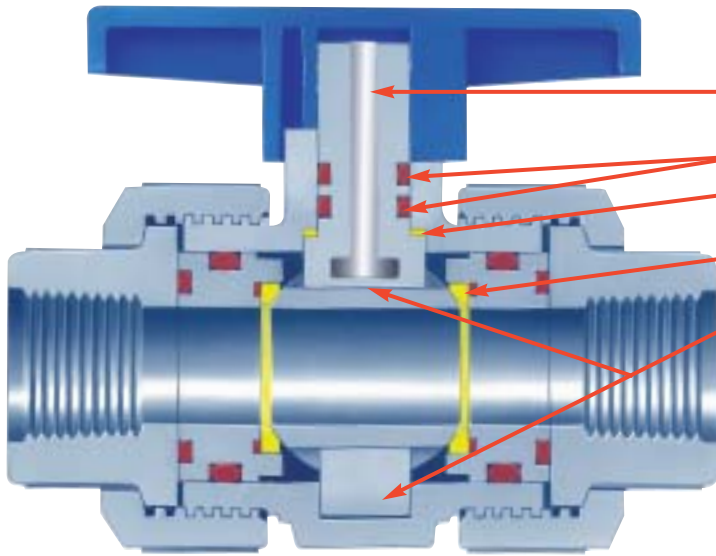

Each valve is 100% individually inspected and tested prior to shipment.

## Features:

- Valve shaft (stem) reinforced with stainless steel rod to eliminate flexing and breakage.
- Dual shaft seals eliminate leakage.
- Teflon® bearing on shaft eliminates friction and wear; stem design is "blow-out" proof.
- Teflon seats energized with O-rings eliminate wear and improve cycle life.
- Trunnion design eliminates lateral ball stress and allows downstream piping to be disconnected under full line pressure.
- Fully concentric and mirror polished ball assures smooth, leakproof operation.
- Multi-direction flow means valve cannot be piped in backwards.
- Smooth flow path eliminates pressure loss.
- True-union ends for ease of piping installation and removal.
- Mounting lugs on body for piping support or easy attachment of True Blue Actuators.

## Design:

Known as "The Engineered Ball Valve", Series MBV provides more safety and design features than any other thermoplastic ball valve. With its mirror-polished ball, perfectly machined sealing surfaces, Trunnion centering design, Teflon thrust bearing and O-ring loaded floating Teflon seats, the True Blue manual ball valve offers smooth turning even in difficult applications. The floating seats automatically compensate for seat wear, and after long-term cycling, the carriers can easily be returned to their original position simply by tightening the union nuts.

The top and bottom "Trunnion" design permits flow and pressure in either direction, and eliminates the stresses inherent to a ball secured only at the top. Sizes 1/2" through 1 1/2" have a full port; size 2" has a tapered port; the ultra smooth flow path virtually eliminates turbulence and pressure loss and permits flow rates that far exceed pipe manufacturers specifications.

Mounting lugs are integrally molded on the sides of each valve. These provide convenient piping support, and allow you to add an actuator in the field with no bulky adapter kits or changeovers. Even after many years, a True Blue Actuator can be added without removing the valve from the piping system.

## Manual Override:

Series MBV is molded of Type 1 Grade 1 Geon® PVC, Corzan® CPVC, Natural Polypropylene, and Kynar® PVDF. Standard O-ring seals are Viton® or EPDM. Seats and shaft bearings are Teflon. Stainless steel shaft reinforcement is not in contact with liquid. Standard connections are threaded (NPT or BSP) or socket (Schedule 80 or Metric). For optional materials and connections, please consult factory.

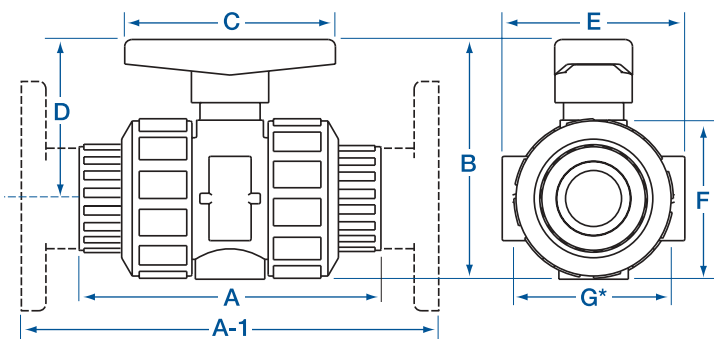

## DIMENSIONS

Pipe Sizes		Weights**		A		A-1		B		C		D		E		F		G*		
NPT	BSP	MM	Lbs.	Kg	Thread	Socket	IN	MM	IN	MM	IN	MM	IN	MM	IN	MM	IN	MM	Bolt Center	
					IN	MM	IN	MM	IN	MM	IN	MM	IN	MM	IN	MM	IN	MM	IN	MM
1/2"		20	.5	.2	4.125	104.8	6.125	155.6	3.0	76.2	3.125	79.4	2.0	50.8	2.25	57.2	2.0	50.8	1.75	44.5
3/4"		25	.8	.3	4.625	117.5	7.125	181.0	3.75	95.3	3.75	95.3	2.5	63.5	2.75	69.9	2.5	63.5	2.25	57.2
1"		32	1.1	.5	5.5	139.7	8.0	203.2	4.312	111.1	3.75	95.3	3.0	76.2	3.25	82.6	3.312	73.0	2.5	63.5
1 1/4"		40	2.3	1.1	6.5	165.1	9.25	235.0	6.125	155.6	4.5	114.3	4.0	101.6	4.125	104.8	4.25	108.0	3.312	84.1
1 1/2"		50	2.5	1.1	6.75	171.5	9.75	247.7	6.125	155.6	4.5	114.3	4.0	101.6	4.125	104.8	4.25	108.0	3.312	84.1
2"		63	2.7	1.2	8.0	203.2	11.375	288.9	6.125	155.6	4.5	114.3	4.0	101.6	4.125	104.8	4.25	108.0	3.312	84.1

\*Center line for bolt holes. \*\*For weight of valve in CPVC multiply by 1.1, for Polypro multiply by .66, and for Kynar® (PVDF) multiply by 1.3.

## Ordering Information

Order by part number and specify exact chemicals, temperatures and pressures. To arrive at the proper part number, please consult diagram below.

The letters and numbers used in this part number are for example only!

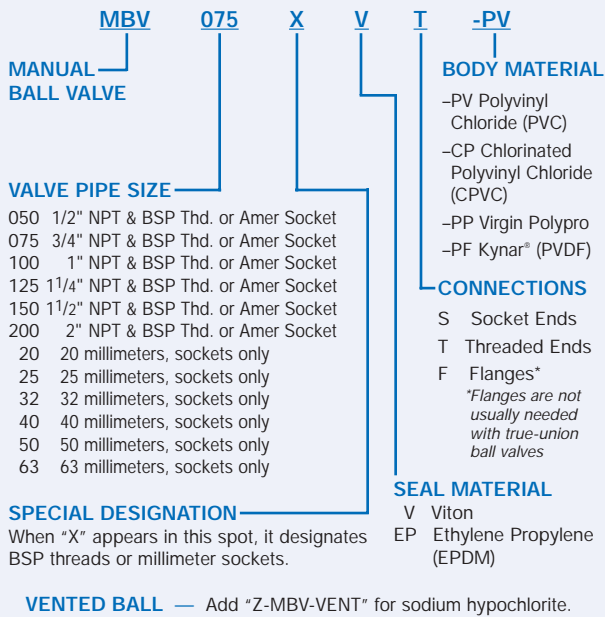

## Material Guideline For Pressure and Temperature

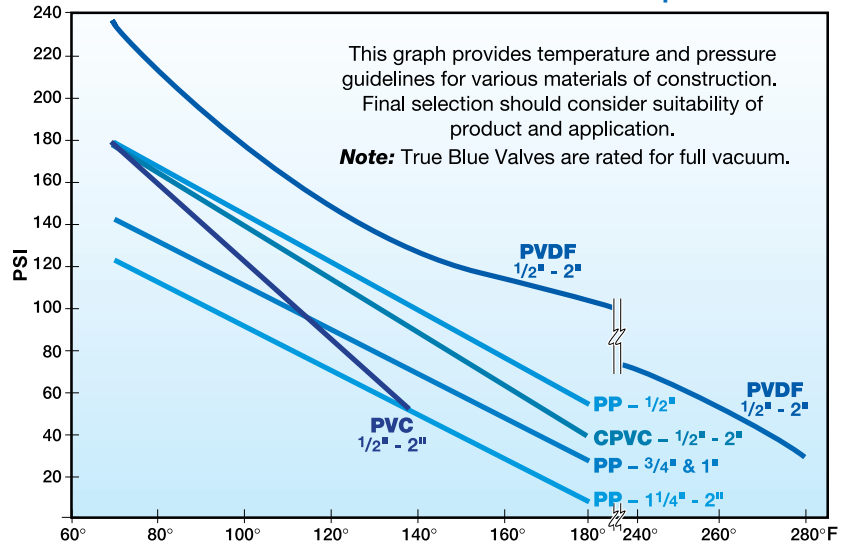

### APPROXIMATE FLOW RATES at 1.0 PSI (0.07 Bar) Pressure Drop

Valve Sizes	1/2	3/4	1	1 1/4	1 1/2	2
<b>Cv Factor</b>	10	20	40	80	100	120
TORQUE SPECIFICATIONS						
<b>Torque in-lbs.</b>	25	35	45	70	70	70



## Natural Polypro Ball Valves

Our Polypropylene True Blue Ball Valves provide a cost-effective option for ultra-pure water handling applications. They are manufactured from natural, unpigmented virgin polypropylene, containing no plasticizers or fillers. In addition, our valves are assembled dry, eliminating contamination via any lubricants. Following is additional information which may be found useful in your evaluation process.

### Characteristics of Natural Polypropylene:

- Homopolymer resin.
- Compatible with all popular homopolymer and copolymer piping.
- Meets all requirements of the U.S. Food and Drug Administration as specified in the Code of Federal Regulations, Title 21, Section 177.1520, covering safe use of articles intended for food-contact use.
- Underwriters Laboratories yellow card index rating (in a minimum thickness of 0.120 in.) 115°C, UL94 Flammability Class 94HB in 0.58 inch thickness.
- NSF-listed for possible water uses, non-pressure applications. Also, NSF-listed for DWV pipe and fittings, continuous waste.
- CAS# 9003-07-0.

### TYPICAL RESIN PROPERTIES

	(a)	(b)
Melt Flow Rate, dg/min	12	ASTM Method D 1238
Density, g/cm <sup>3</sup>	0.903	D 792A-2
Notched Izod Compact Strength		
ft.-lbs/in. (J/m), at 73°F	0.7 (37.3)	
ft.-lbs/in. (J/m), at 0°F	0.3 (16)	
Tensile Strength at Yield PSI (MPa)	5,000 (34.5)	D 638
Elongation at Yield, %	11	D 638
Flexural Modulus, PSI (MPa)	240,000 (1,655)	D 790B
Rockwell Hardness, R Scale	100	D 785A
Deflection Temperature at 66°F (455kPa), °F (°C)	198° (92°)	D 648
Water Absorption after 24 Hrs., %	0.02	D 570
Environmental Stress-Cracking, hrs.	500, No Failure	D1693
Coefficient of Linear Thermal Expansion, cm/cm/°C:		
-30 - 0°C	6.4 x 10 <sup>-5</sup>	
0 - 30°C	8.6 x 10 <sup>-5</sup>	
30 - 60°C	9.4 x 10 <sup>-5</sup>	

(a) Values shown are averages and are not to be considered specifications.

(b) ASTM test methods are latest under Society's current procedures.

All molded specimens prepared by injection (ASTMD 2146).