

## CORZAN CPVC Thermoplastic Pressure Regulators

Permits Downstream Pressure Settings From 5 to 125 PSI

Designed for Higher Temperature Ratings with Outstanding Chemical Resistance



### Superior Features:

- Converts varying inlet pressure up to 150 PSI, to a stabilized, lower pre-set downstream pressure.
- Protects sensitive downstream instruments, tubing and filters against damage from overpressure/pressure surges; permits the entire system to operate safely and effectively.
- Downstream pressure settings adjustable from 5 to 125 PSI.
- Large surface area of its frictionless rolling diaphragm provides exceptional sensitivity.
- Free movement of the diaphragm on a balanced shaft assures smooth, accurate performance and reliable sealing for millions of cycles.
- Double U-cups prevent leakage along the shaft and eliminates the possibility of “creep”.
- Optional gauge ports to assist with setting and monitoring pressure.
- For corrosive and ultra-pure liquid applications.

### Materials of Construction and Piping Connections:

- Body is Corzan CPVC.
- Seals are FKM (Viton) or EPDM.
- Connections are available NPT, socket, spigot, flange.

### Pressure Regulator Selection:

In the selection of a liquid pressure regulator, flow capacity with minimum system pressure loss are critical criteria, but it should be recognized that all similar-size competitive regulators do not provide similar performance levels. These regulators provide not only higher set pressures and flow capacities with each model, but these are achieved with less pressure losses than with similar size competitive regulators. These lower pressure drop-offs can be seen from the performance curve chart shown on the next page.



**PLAST-O-MATIC VALVES, INC.**

1384 Pompton Avenue, Cedar Grove, New Jersey 07009-1095

(973) 256-3000 • Fax (973) 256-4745 • [www.plastomatic.com](http://www.plastomatic.com)

# PLAST-O-MATIC PRESSURE REGULATORS

## Design:

Plast-O-Matic Pressure Regulators are designed to handle corrosive and ultra-pure liquids with inlet pressures up to 150 PSI at 75°F. Standard down-stream set pressure range is 5 to 125 PSI. The normally-open regulators incorporate a poppet seat at the valve orifice to prevent sticking and affecting the sensing of the downstream line pressure. Also, one piece body construction and dual U-cup shaft seals help to eliminate internal leakage that could cause the set pressure to creep beyond a safe limit. A unique, large-surface, rolling diaphragm seal isolates the spring chamber from downstream pressure sensing liquid. This unique design, in conjunction with a pressure balanced shaft, assures smooth performance and stable control. **CAUTION:** Avoid quick closing valve downstream of a regulator to eliminate "water hammer" shock that can cause breakage.

## Operation:

Pressure regulators prevent downstream pressure from exceeding the desired set pressure. Regulator will remain closed as long as set pressure is maintained. As equipment or valves downstream of regulator begin to open and demand flow, the downstream pressure begins to fall and the regulator begins to open. As valves or equipment downstream open further, the pressure regulator continues to open until the maximum opening is reached. As the process is reversed, downstream pressure begins to increase and the regulator starts closing. When the downstream pressure again reaches set pressure the regulator closes bubble-tight. **IMPORTANT:** It should be noted from the preceding explanation that a pressure regulator does not maintain a specific downstream pressure, but *only* prevents the downstream pressure from exceeding a set point.

## Typical Performance Curves of Flow vs. Drop Off From Set Pressure:

Drop-off is the difference between the pressure regulator set pressure and the downstream pressure. Performance curves chart at right identifies the high flow capacities and the low pressure drop-off of Plast-O-Matic regulators which result in their greater sensitivity, finer adjustability and superior accuracy as compared to competitive models.

### TYPICAL PRESSURE REGULATORS

#### PERFORMANCE CURVES:

#### Flow Capacity vs. Pressure Drop-Off (PSI)

#### Comparison of Representative Plast-O-Matic Models with Competitors

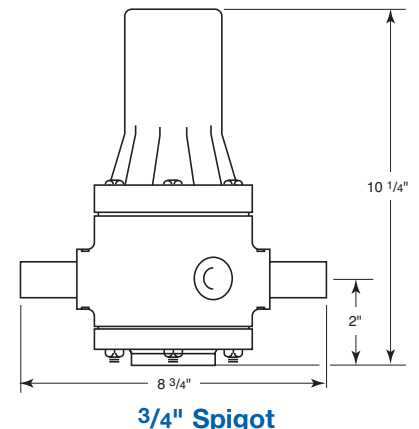
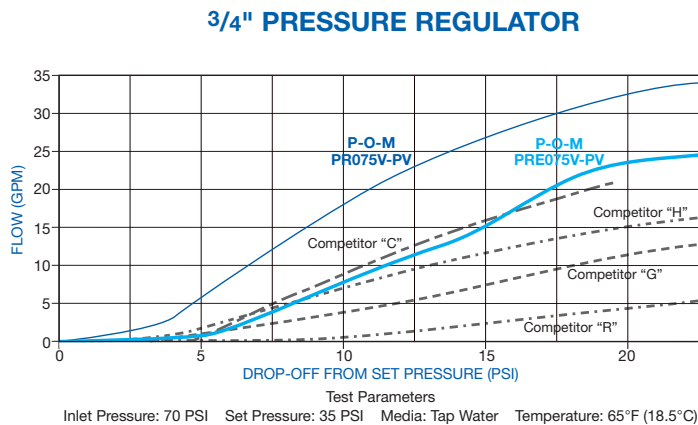
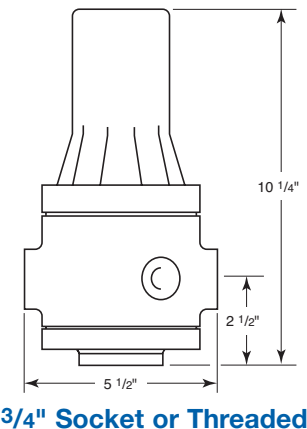
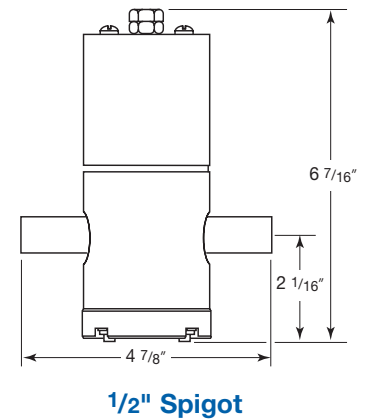
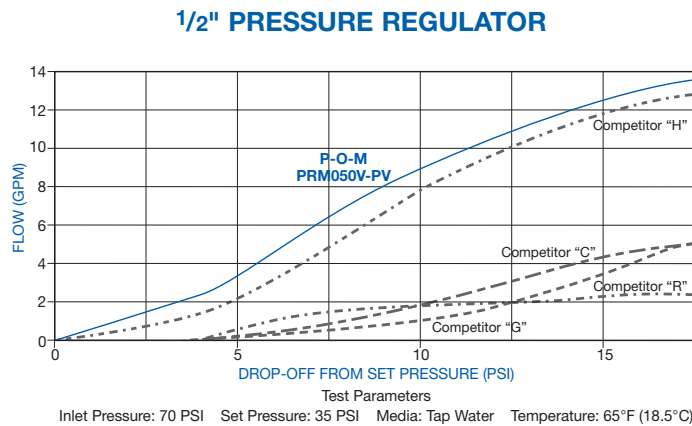
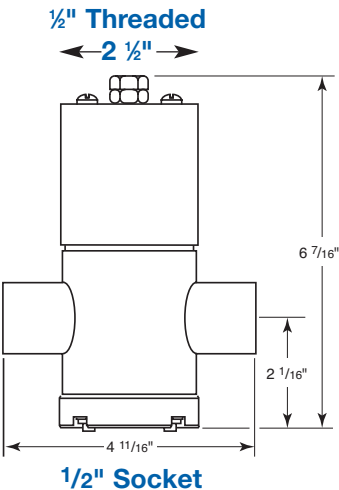

# PLAST-O-MATIC CORZAN CPVC PRESSURE REGULATORS

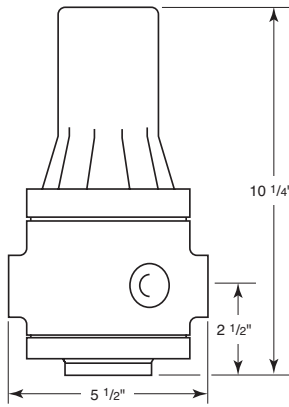

**1" Socket or Threaded**

## 1" PRESSURE REGULATOR

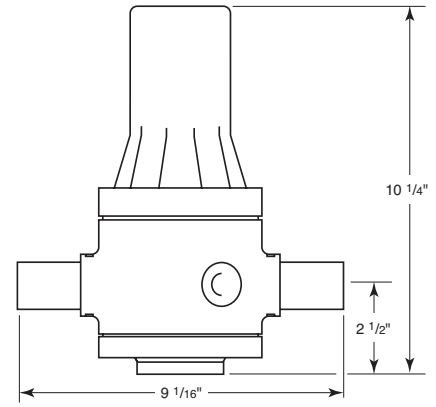
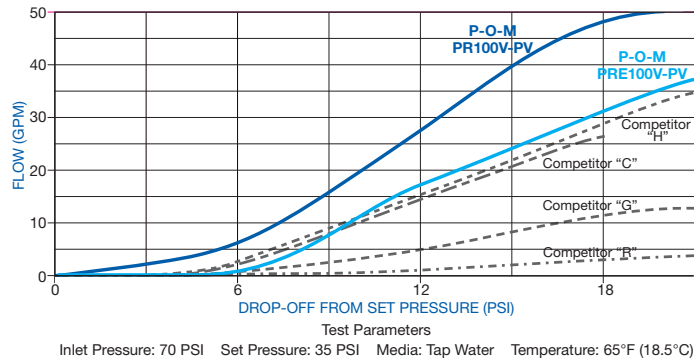

**1" Spigot**

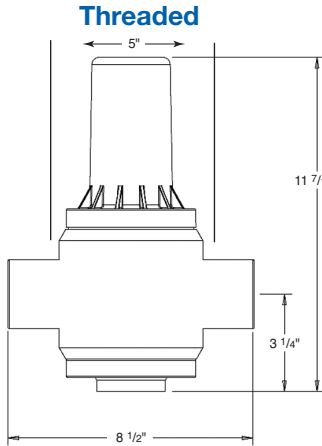

**1 1/2" Socket**

## 1 1/2" PRESSURE REGULATOR

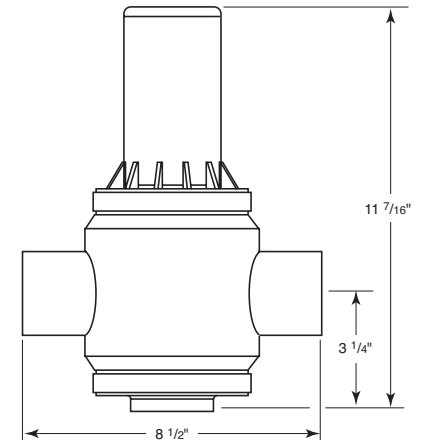
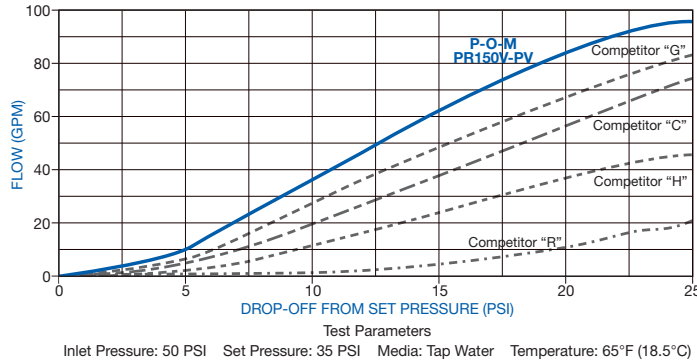

**1 1/2" Spigot**

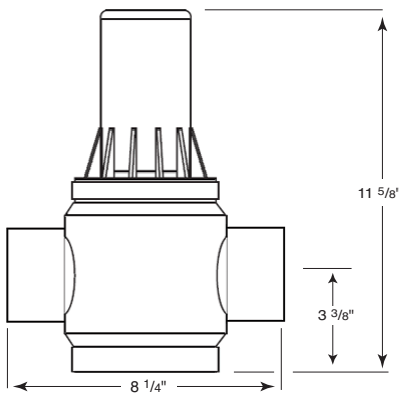

**2" Socket or Threaded**

## 2" PRESSURE REGULATOR

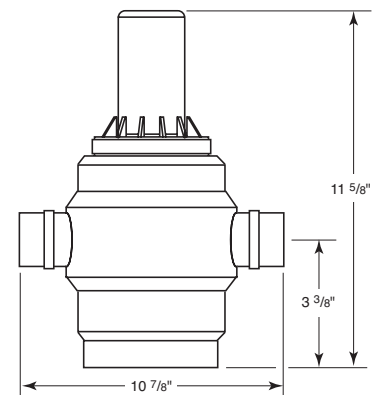
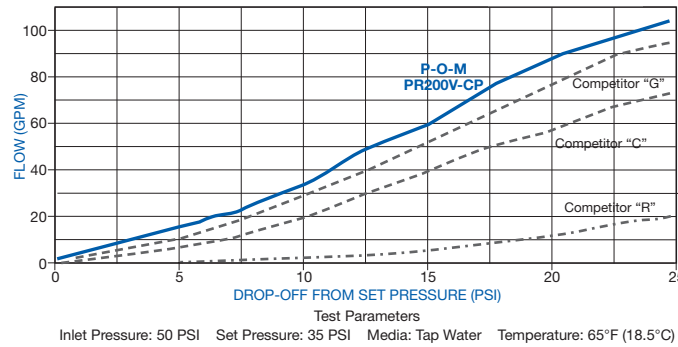

**2" Spigot**

The drop-off is the difference between the pressure regulator set pressure and the downstream pressure.

NOTE: All data for these curves was collected from actual flow tests at Plast-O-Matic Valves, Inc., Cedar Grove, NJ. or manufacturer's published performance data. The measuring equipment used was the same for all regulators tested, and the relative results between different models are considered to be an accurate portrayal of the data.

# PLAST-O-MATIC PRESSURE REGULATORS

## 3" PRESSURE REGULATOR (Consult Factory)

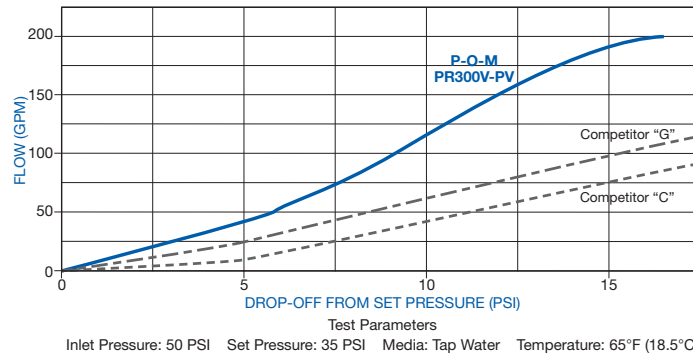

### Series "PRH" Model Number

Valve Size	Threaded	Sockets	Spigots
1/2"	PRH050EP-CP	PRH050XEP-S-CP	PRH050XEP-SP-CP
3/4"	PRHM075EP-CP	PRHM075EP-S-CP	PRHM075EP-SP-CP
1"	PRHM100EP-CP	PRHM100EP-S-CP	PRHM100EP-SP-CP
1 1/2"	PRH150EP-CP	PRH150EP-S-CP	PRH150EP-SP-CP
2"	PRH200XEP-CP	PRH200XEP-S-CP	PRH200XEP-SP-CP
3"	PRH300XEP-CP	PRH300XEP-S-CP	PRH300XEP-SP-CP

Part numbers shown are CPVC body, EPDM seals. For VITON Seals, change "EP" to "V", for example, PRH050XV-CP. For other body materials, consult factory.

**PLAST-O-MATIC**  
VALVES, INC.

1384 Pompton Avenue, Cedar Grove, NJ 07009  
(973) 256-3000 • Fax (973) 256-4745  
www.plastomatic.com • info@plastomatic.com

AUTHORIZED PLAST-O-MATIC DISTRIBUTOR