

## **NEW!** Three-Way Solenoid Valves For Corrosive and Ultra-Pure Liquids 1/4" and 1/2" Sizes – Inlet and Back Pressures to 100 PSI

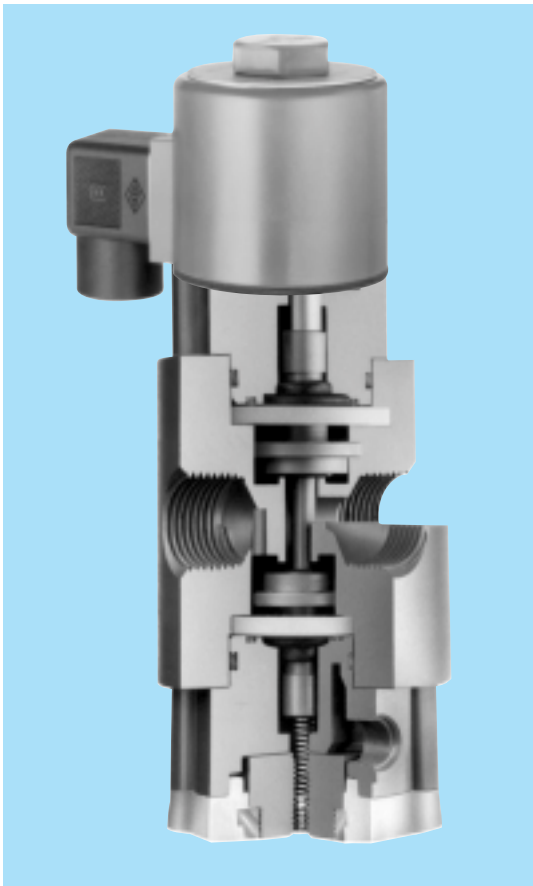

### **Series THP:**

Compact, direct acting thermoplastic solenoid valves, specifically designed for high-inlet and high back pressure applications.

### **Features:**

- Balanced shaft design permits higher pressures.
- Bubble-tight sealing.
- No metal parts in wetted area.
- Patented Fail-Dry™ safety design provides warning of seal failure while allowing valve to continue functioning.

### **Application:**

Series THP, three-way solenoid valves are used to divert flows from a common inlet to either of two outlets. The valves are ideal for sprayhead or filter applications where high back pressures exist. Recommended for handling corrosive or ultra-pure liquids. Standard valve is not designed for vacuum service; consult factory if needed.

### **Important Note on 2-Way Valve Usage:**

Can be converted to two-way valve by plugging appropriate outlet. See Note 3 under "Specifications and Model Numbers".

### **Materials of Construction:**

Valves are constructed of PVC with EPDM or Viton® diaphragms. Stainless steel fasteners are standard and are not in wetted areas. A 20 watt all-plastic molded coil is standard and is available in 24, 120, 240 or 480 VAC. Consult factory for D.C. voltage and for other body materials.

### **Design:**

These solenoid valves are direct-acting. They have an upper and lower diaphragm separating the liquid from opposing springs. There is no metal in the liquid section of the valves. In cycle tests they have been run successfully to 1,000,000 cycles with EPDM diaphragms, and 100,000 cycles with Viton® diaphragms under laboratory conditions. Field performance may vary.

# THREE-WAY SOLENOID VALVES

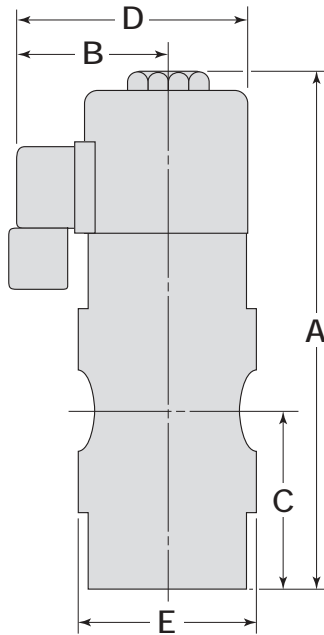

| SERIES THP DIMENSIONS |     |       |     |      |     |      |     |      |     |      |
|-----------------------|-----|-------|-----|------|-----|------|-----|------|-----|------|
| Size                  | In. | A mm  | In. | B mm | In. | C mm | In. | D mm | In. | E mm |
| 1/4                   | 7.7 | 195.6 | 2.4 | 60.9 | 2.6 | 66.1 | 3.6 | 91.4 | 2.5 | 63.5 |
| 1/2                   | 7.7 | 195.6 | 2.4 | 60.9 | 2.6 | 66.1 | 3.6 | 91.4 | 2.5 | 63.5 |

## FLOW PATTERN (Top View of Valve Shown)

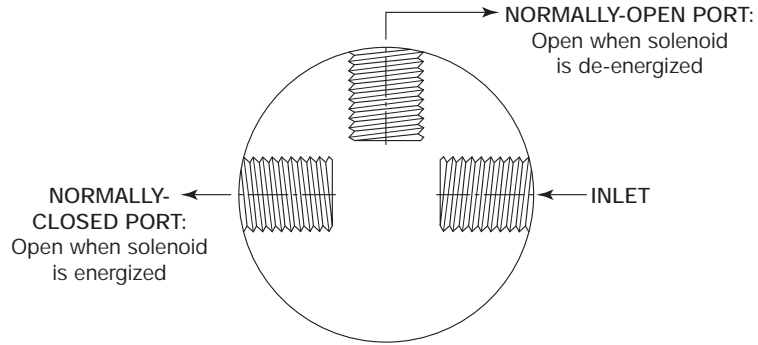

| SERIES THP SPECIFICATIONS AND MODEL NUMBERS |              |     |                       |                        |      |                       |      |              |             |
|---|--------------|-----|-----------------------|------------------------|------|-----------------------|------|--------------|-------------|
| Pipe Size In.                               | Orifice Size |     | C <sub>v</sub> Factor | Maximum Inlet Pressure |      | Maximum Back Pressure |      | Model Number |             |
|   | In.          | mm  |                       | PSI                    | Bars | PSI                   | Bars | EPDM Seals   | Viton Seals |
| 1/4   | 1/8          | 3.2 | .31                   | 100                    | 6,9  | 100                   | 6,9  | THP2EP4W20   | THP2V4W20   |
|   | 3/16         | 4.8 | .52                   | 70                     | 4,8  | 70                    | 4,8  | THP2EP6W20   | THP2V6W20   |
|   | 1/4          | 6.4 | .61                   | 40                     | 2,8  | 40                    | 2,8  | THP2EP8W20   | THP2V8W20   |
| 1/2   | 1/8          | 3.2 | .31                   | 100                    | 6,9  | 100                   | 6,9  | THP4EP4W20   | THP4V4W20   |
|   | 3/16         | 4.8 | .52                   | 70                     | 4,8  | 70                    | 4,8  | THP4EP6W20   | THP4V6W20   |
|   | 1/4          | 6.4 | .61                   | 40                     | 2,8  | 40                    | 2,8  | THP4EP8W20   | THP4V8W20   |

- NOTES:**
1. The maximum pressure differential ( $\Delta P$ ) is the same as the maximum inlet pressure.
  2. 1/8" and 3/8" sizes are available in quantity purchases of 25 each (minimum), by request.
  3. It is possible to create either a normally-open or normally-closed 2-way valve by simply plugging the appropriate outlet. The maximum ratings for this (2-way) valve are 40 PSI (4.1 Bar) inlet and 40 PSI (4.1 Bar) backpressure with a 1/4" orifice and .61 Cv.

### Temperature Information:

Pressure ratings in table are at 75°F (24°C). Maximum temperature rating of PVC is 140°F (60°C) and the maximum pressure rating at this temperature is 40 PSI (2,7 Bar). At 122°F (50°C) the maximum pressure rating is 60 PSI (4,1 Bar).

### Ordering Information:

Order by model number and specify coil voltage. Model numbers listed are for W20 NEMA 4X style coils. For General Purpose coils, change "W20" to "G20". For Explosion-proof coils change "W20" to "E20".

AUTHORIZED PLAST-O-MATIC DISTRIBUTOR