

Ultra-Pure Pressure Regulator Series UPR



Features:

- Non-shutoff design, will pressure balance under no-flow condition. For positive shutoff version, consult factory.
- All thermoplastic construction, no elastomers used in non-shutoff version.
- Standard connections: PVDF butt-fusion for Asahi or GF high purity piping systems. Flare and other types available; consult factory.
- High performance regulator provides maximum flow with minimal pressure loss downstream.
- No metal components other than a non-wetted, PVDF coated spring.
- Variable area diaphragm provides excellent sensitivity.
- Multi-turn pressure adjustment provides accurate, infinite settings.
- Maximum inlet pressure 150 PSI
- High purity 8 hour hot DI rinse and CDB procedure is standard; clean and double bag in class 100 (ISO 5) clean room.
- Non-wetted parts available in ABS to reduce costs; consult factory.

Series	Size	Diaphragm	Body Material	Spigot Connection
UPR(L)	050	T	PF	SPn
UPRL	1/2" - 050	TFM	PVDF	Asahi - SP 1
5-50	3/4" - 075			GF - SP 2
PSI Set	1" - 100			
UPR	1 1/2" - 150			
5-100	2" - 200			
PSI Set	2 1/2" - 250			

PERFORMANCE CURVES

1/2" UPRL050T-PF

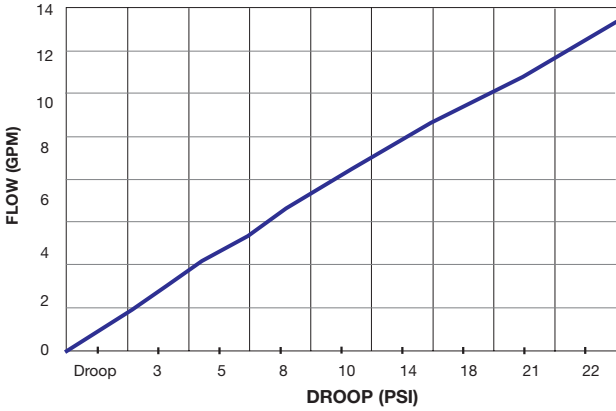

3/4" UPRL075T-PF

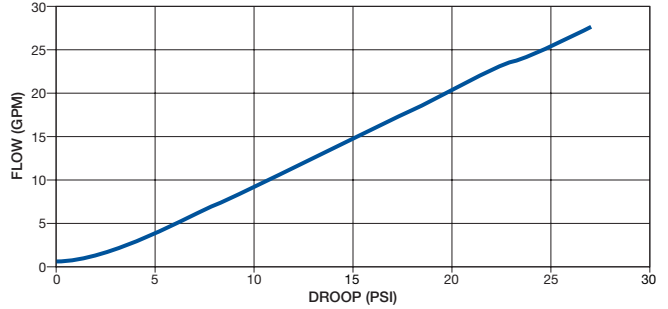

1" UPRL100T-PF

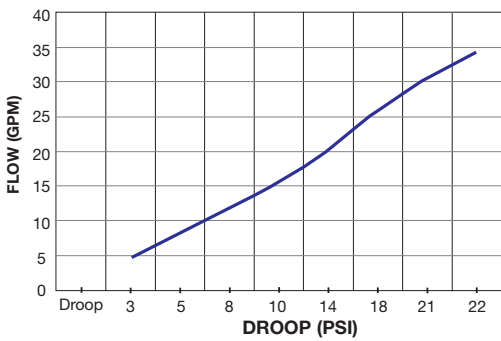

1 1/2" UPRL150T-PF

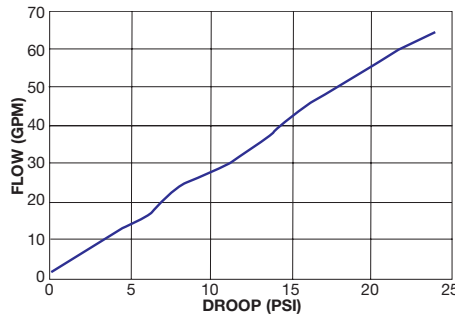

2" UPRL200T-PF

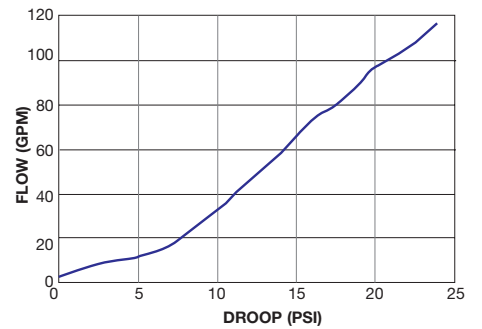

Tests performed with city water 70 PSI inlet @ 75°F. with test regulators set at 35 psi outlet.

DIMENSIONS

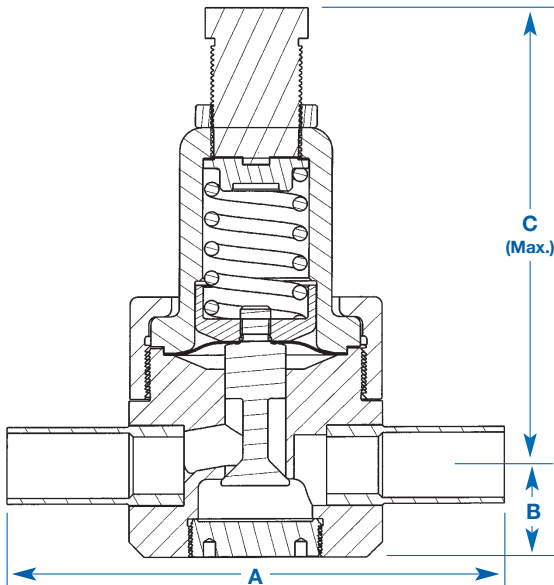

Pipe Size		A		B		C	
IN.	MM	IN.	MM	IN.	MM	IN.	MM
1/2"	20	7"	178	1 1/4"	32	6 11/16"	170
3/4"	25	7 7/8"	200	1 3/8"	35	7 1/2"	191
1"	32	8 5/32"	208	1 1/2"	39	9 1/16"	233
1 1/2"	50	9 31/32"	254	2 9/16"	65	12 3/16"	310
2"	63	10 3/32"	257	3 3/16"	81	12 3/8"	314
2 1/2"	75	13 1/2"	343	5"	127	13"	331

CAUTIONARY NOTES:

1. This regulator will never close off flow completely. It **DOES NOT** provide positive shut-off. Therefore, if the demand goes below that value at which the regulator was set, the outlet pressure will rise above the set point and if the demand is stopped (no flow condition) the outlet pressure will rise up to the value of the inlet pressure. If excessive pressure can damage downstream equipment a shut-off valve must be placed between the regulator and the equipment in question.
2. Quick closing valves installed downstream of the regulator can cause water hammer. This may cause leakage, diaphragm or seal damage.

PLAST-O-MATIC
VALVES, INC.

1384 Pompton Avenue, Cedar Grove, NJ 07009
(973) 256-3000 • Fax (973) 256-4745
www.plastomatic.com • info@plastomatic.com

AUTHORIZED PLAST-O-MATIC DISTRIBUTOR